



800.998.MATE | www.autom8.com | 650 University Ave #5, Berkeley, CA 94710 USA
tel 510.845.6283 | fax 510.665.3975 | e-mail info@autom8.com

Innovative Engineering for Science

BRAIN SLICE CHAMBER SYSTEM

BSC3

BRAIN SLICE CHAMBER

CAUTION !

YOUR BRAIN SLICE CHAMBER IS A PRECISION ENGINEERED TOOL FOR SCIENTIFIC INVESTIGATIONS. PLEASE TAKE A FEW MINUTES TO FAMILIARISE YOURSELF WITH THE CHAMBER AND READ THROUGH THIS SHORT MANUAL BEFORE ATTEMPTING TO USE THE SYSTEM.

DO NOT UNDER ANY CIRCUMSTANCES OPERATE THE PTC03 TEMPERATURE CONTROLLER AND BRAIN SLICE CHAMBER WITHOUT ADEQUATE WATER IN THE LOWER CHAMBER OR WITH THE SENSOR PROBE REMOVED FROM THE CHAMBER END. THIS CAN CAUSE OVER-HEATING OF THE HEATER ELEMENT. A THERMAL FUSE IS LOCATED IN THE SLICE CHAMBER TO PREVENT WATER TEMPERATURE RISING ABOVE 70°C.

DO NOT USE ALCOHOL OR SIMILAR SOLVENTS IN ANY CONCENTRATION ON ANY PART OF THE CHAMBER SINCE AS WITH MOST ACRYLICS, TAMPERSPEX MAY FRAGMENT OR DEVELOP HAIR-LINE CRACKS.

<u>CONTENTS</u>	<u>SECTION</u>
1) CHAMBER DESCRIPTION	I
2) CONSTRUCTION	I
3) METHODS OF PERFUSION	II
Interface	
Submerged	
4) OXYGENATION	III
Interface	
Submerged	
5) TEMPERATURE	IV
Proportional Temperature Controller PTC03	
Description	
Specifications of PTC03	
Interface	
Submerged	
6) INSTALLATION AND OPERATION	V
Schematic Diagram	
Location	
Filling Lower Chamber	
Connection to Gas Mixture Source	
Connection to Temperature Controller	
Connection of Exit Well	
Schematic Diagram	
Connection of the Perfusion Fluid Source	
Reference Electrode Connections	
7) MAINTENANCE	VI
Replacing Nylon Net under 'C' Insert	

I

CHAMBER DESCRIPTION

The BSC3 Brain Slice Chamber consists of either four or six independent channels each designed to maintain isolated, living tissues *in vitro* and allow pharmacology and electrophysiology experiments to be conducted on the preparation. Both "interface" and "submerged" methods of maintaining slices can be achieved with the same chamber without any additions. Temperature is maintained by the PTC03 proportional control heating unit which is ordered with the system.

CONSTRUCTION

The chamber is constructed from clear acrylic in three sections. The upper part contains the individual chambers and has a diameter of 130mm. The middle part contains the heating and sensing elements for temperature control and a ceramic bubbler for the supply of oxygen which is humidified by its passage through the heated distilled water in this compartment. The base plate forms the third part and is used to secure the chamber in the experimental rig. The overall height of the BSC3 is 80mm. In each of the individual chambers machined in the upper part, the slices rest on a nylon net held in place by a close fitting 'C' shaped removable insert. Pre-oxygenated medium enters the main body of the chamber through a fine bore PTFE tube which spirals in the heated distilled water in the lower part of the chamber and enters the upper part of the chamber directly into the feed for each of the individual chambers. An input channel directs the perfusate to the slice and then out to a well where it is sucked off. Depending on whether submerged or interface type preparations are required, the height of the perfusion fluid is adjusted at the exit well by means of a variable angle stainless steel tube.

II

METHODS OF PERFUSION

Interface preparations are normally used for exploration of field potentials since they offer good visualisation of laminated regions such as cell body layers which appear relatively translucent. The perfusion fluid bathes only one side. Submerged preparations offer fluid exchanges over both slice surfaces when experimenting with ionic concentrations and perfusion of drugs. However, dead space has to be taken into consideration as the test solution will take longer to rinse out.

INTERFACE

In this type of preparation the height of the perfusion fluid is adjusted so that it is virtually at the same level as the surface of the slice resting on the nylon net. In this way the solution forms a very thin film over the slice keeping it moist. A high oxygen tension in high humidity must be maintained above the slice. With Krebs solutions, this is achieved by passing a 95% oxygen, 5% carbon dioxide gas mixture through a bubbler located in the lower part of the chamber containing heated distilled water. The pre-oxygenated incoming perfusion fluid is warmed as it spirals in the heated distilled water contained in the lower part. This tube then enters the upper part of the chamber into the entry well of the chamber. Perfusate is then channelled towards the nylon net on which the slice is supported, usually resting on a piece of lens tissue. The solution then exits through a well where it is removed by means of a stainless steel tube attached to a suction line. This is an

'L' shaped tube that allows the height of the end to be adjusted by turning the plastic screw fitting in which it is held. This allows the fluid level to be set to the desired level and maintained constant, usually at the level of the surface of the slice.

SUBMERGED

In this type of preparation the solution height is adjusted to be above the surface of the slice, by approximately 0.5mm. The perfusion fluid flows towards the nylon net as before, then around the slice before exiting through the well. The oxygenation of the slice is then provided primarily by the oxygenated perfusion solution.

III

OXYGENATION

INTERFACE

The oxygen tension above the slice is maintained by an inflow of a pre-moistened 95% oxygen, 5% carbon dioxide gas mixture from the warmed lower part of the recording chamber. The gas enters the upper section through two holes at the rear end of each individual chamber and is maintained in high concentration by positioning the acrylic lid supplied (or rectangular glass coverslips) over the chamber. In interface mode there is a critical balance such that the gas coming from the bottom is not so fast that it causes the surface of the slices to dry out. When low gas flow rates are utilised in interface mode it is critically important to ensure that a high oxygen concentration is maintained by reducing the opening in the lid as much as possible. This can be done by overlaying small square glass coverslips over the hole in the acrylic lid whilst still allowing electrodes access from above if desired.

As an alternative to the acrylic lids with holes supplied with the chamber, it is possible to use standard 22 by 40mm glass coverslips which are also provided. These would be used if access to the slices is not required and contain the flow of oxygen over the preparation, with the excess gas exiting towards the exit well of the chamber. The corners of the coverslips slightly overlap and for this reason the corners have been ground in order to fit without causing interference between the separate chamber wells.

If there is too much condensation from the vents on to the coverslips, it means that there is too big a differential between the slice temperature and room temperature. You may need to point a standard microscope lamp (which has some small heat output) on to the central part of the upper chamber so that the glass coverslips heat up but the heat source should be arranged obliquely so as not heat up the slices too.

SUBMERGED

A high perfusion fluid flow rate is usually employed with this type of preparation, the pre-oxygenated solution around the slice normally carries all the required oxygen. The flow of oxygen above the slice is therefore not as critical and for this reason it is sometimes permissible to remove the lid altogether to give greater access for positioning the recording/stimulating electrodes.

IV

TEMPERATURE

PROPORTIONAL TEMPERATURE CONTROLLER PTC03

DESCRIPTION

The PTC03 is a temperature control unit for use with the slice chamber. A low voltage direct current output with low noise characteristics is used to power the heating element contained within the lower chamber together with a sensor for feedback proportional control. The required temperature is set using the front panel control with a digital readout of set temperature. When the display selector is set to control the display reads the temperature of the control sensor. Provision is also made to display the temperature from an optional monitor sensor if this is being used. Full control is reached within 20 minutes at a setting of 40°C, with an ambient of 20°C. Set temperature must exceed ambient by 2 °C minimum.

SPECIFICATIONS OF PTC03

Readout accuracy	+/- 0.1 degrees centigrade
Control accuracy	0.5°C below set temperature maximum difference.
Control stability	Not more than +/- 0.1°C from control point.
Output power	36 Watts Max.
Output type	D.C. Proportional control
Sensors	Pt100 Platinum Resistance (Control & Monitor)
Power requirements	110V / 240V +/- 10% 60/50Hz, 50 W (specified on order).
Dimensions mm	90H x 260W x 260D
Weight	4 Kg

INTERFACE

The upper chamber temperature is maintained by ensuring that the gas mixture and the physiological solution enter at the required temperature, this is dependent on the temperature of the body of the chamber which is warmed by a heating element controlled by the PTC03. The whole system reaches equilibrium within 20 minutes.

SUBMERGED

The higher flow rate used with this method allows a more rapid settling of the final temperature. Again with this method the inflow of pre-warmed gas mixture can be reduced as it will only have a minor contribution to the final temperature, however it is necessary to maintain gassing in the lower chamber as this provides a stirring action enabling efficient heat transfer between the heater and sensor probe of the PTC03.

ALTERNATIVE METHODS OF TEMPERATURE CONTROL

Both the heating element and temperature sensor probe can be unscrewed to allow an alternative method of heating to be used with the chamber. Adaptors are available to replace the two hole positions with a heat exchanger which can be fed from a circulating hot/cold water bath. Please ask for further details.

V

INSTALLATION AND OPERATION

If a complete system was purchased, your parcel should contain both the Brain Slice Chamber and the PTC03 Temperature Controller. Once all packing material has been removed, PLEASE take some time to examine the construction of the chamber. Please do not attempt to dismantle the chamber at this stage, it should rarely be necessary to do so.

SCHEMATIC DIAGRAM

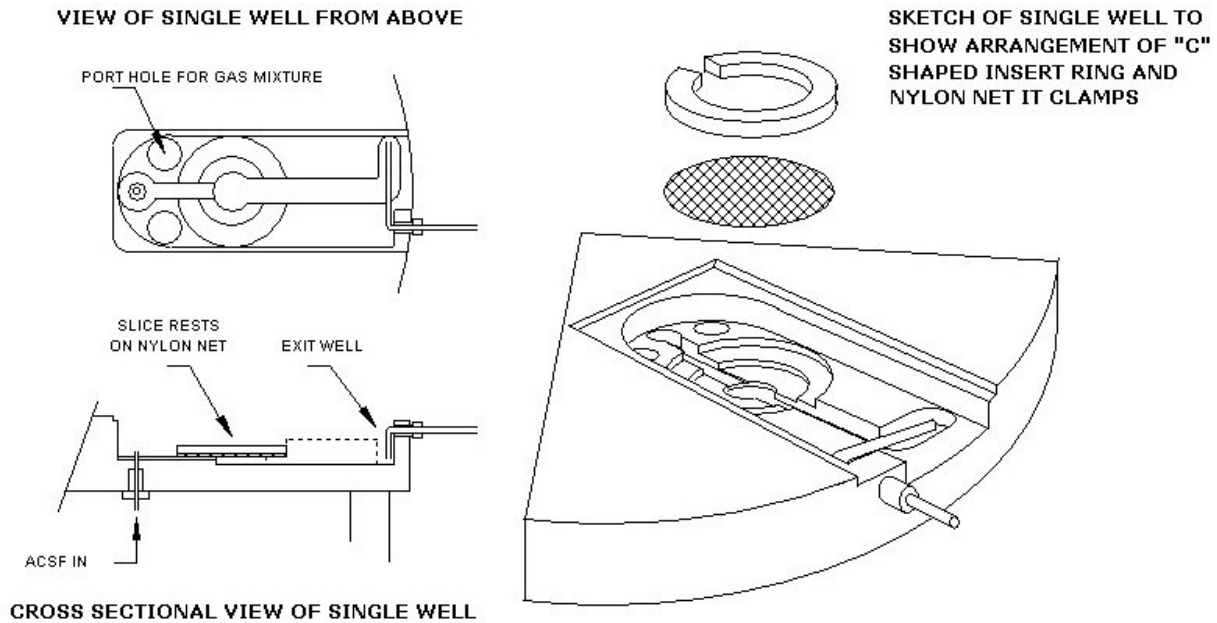

LOCATION

The chamber should be secured to a solid, smooth table surface such as marble or steel. (Steel should either be coated with an anti-corrosive film or nickel electro-plated). The four 90 degree or the three 120 degree pattern fixing holes in the base can be used to mount small magnetic bases if a steel table is used as a base. The base-plate must not become distorted through securing on to an uneven base, nor should nuts and bolts be over tightened in the holes provided.

FILLING LOWER CHAMBER

Once secured, fill the lower chamber with approx 110 mls of distilled water using a syringe fitted with a plastic tube capable of being inserted into one of the eight vent holes on the upper section. Make a note of the fill level which should be seen to completely immerse the heating element visible in the lower chamber and be 2 to 4 mm below the junction between the upper and lower sections. Check this level routinely on a daily basis before switching on the power to the system. If you see frothing in the lower chamber it means that there is contamination from the ASCF above, you will have to rinse out and start again. Once a week at the end of the day switch off the power and use a fast vacuum

line to suck out as much as possible the distilled water in the lower section, rinse and refill with fresh distilled water as before to the correct level before switching on power. This operation prevents the growth of foreign matter. Never add growth inhibitors or other additives to the distilled water as the atomisation through bubbling can cause particles to enter the upper chamber and contaminate the slices.

CONNECTION TO GAS MIXTURE SOURCE

The gas mixture source should in addition to its reduction valve have a secondary flow regulator for fine adjustments. It is also preferable to pre-moisten the gas supply by passing through a sintered glass bubbler in a "gas wash bottle". Select a glass wash bottle at least 300mm tall (one foot). This is because gas supplied from a cylinder is completely dry, the only chance it will have to gain moisture will be the short "path length" of 40mm within the slice chamber. Once connected adjust the flow rate according to whether interface or submerged mode is being utilised. In addition to providing warmed and moistened gas to the upper chamber, this gassing is necessary to keep the lower section distilled water stirred for efficient feed-back from the heater to the sensor connected to the PTC03 Temperature Controller.

CONNECTION TO TEMPERATURE CONTROLLER

Check that the SENSOR probe is inserted into its hole and that the plug end is connected to the PTC03 Temperature Controller SENSOR socket. Connect the heater power cable from the chamber to the HEATER socket on the PTC03 Temperature Controller. Connect the mains power lead to a suitable socket **WHICH MUST HAVE AN EARTH CONNECTION** for safety and low noise operation. Turn on the power switch located on the rear of the PTC03. On the front panel the "LINE ON" light should now be on. Move the selector switch to "SET", a light above the temperature adjustment knob will turn on to indicate "SET" mode. Adjust the knob and read the LCD display to set to a desired temperature in °C. Once set move the selector switch to "CONTROL". Assuming you have selected a temperature at least two degrees above ambient, the "HEATER ON" light will glow brightly or dimly depending on how close the lower chamber temperature is to the set temperature.

NOTE. The temperature shown on the LCD display will be the temperature of the lower chamber distilled water. The temperature achieved in the upper chamber at the location of the preparation depends on a number of factors principally:-

- 1) Whether the preparation is in "interface" or "submerged" mode
- 2) Ambient temperature
- 3) Incoming gas mixture flow rate
- 4) Perfusion fluid flow rate and initial temperature (e.g. from the refrigerator?)
- 5) Whether chamber lid is in position

Since the above factors are quite stable during the course of an experiment, there is a fixed temperature differential between the upper and lower sections of 3 to 4 degrees for interface and submerged modes. Given this differential, the PTC03 effectively controls the upper chamber temperature which should be monitored with an independent miniature (eg. thermo-couple type) temperature probe. Allow at least 10 to 15 minutes for the system to equilibrate, and approximately 5 minutes for a 5°C temperature increase but 20 to 30 minutes for a 5°C temperature decrease.

As part of our program of continual improvements, provision is already made on your PTC03 circuitry for a plug-in monitor temperature sensor (select MONITOR on switch). This sensor will be available in the future.

CONNECTION OF EXIT WELL

Submerged and interface modes will both require operation of the exit well from which the fluid height is set. The BSC3 has an 'L' shaped stainless steel tube with a special tip designed to suck air and fluid so that only excess fluid is removed. By varying the angle of the tube, the tip height is altered, thereby allowing fluid height to be set. There are two methods by which this can be utilised - either by connection to a fast vacuum line or attaching to a peristaltic pump.

IMPORTANT NOTE

If you are using the chamber for the first time after receiving it, or if the chamber has been cleaned and stored for a long time, it will be necessary to flood each of the individual chambers with a normal saline solution or (ACSF without glucose added) for at least 12 hours. Make sure that the 'L' steel tubes are also submerged in this solution. The reason for this is that newly machined acrylic and other polished surfaces are hydrophobic and will exhibit surface tension effects that cause unstable fluid level control. Since acrylic absorbs a very small amount of water, salt solutions adhere to the surface and overcome the hydrophobic surface tension (positive meniscus) effects after the acrylic has been "wetted" in this way. After 12 hours rinse out all the chambers before beginning setting up with new ACSF.

Fast Vacuum Line

If the perfusate is not being collected or re-circulated, a fast vacuum line connected to a waste "reservoir" can be utilised for each of the chamber exit wells. The 'L' tube end height is set by turning the plastic screw fitting in which the tube is held or by sliding the tube within the plastic fitting. Raising or lowering the end of the tube will cause fluid to be sucked off at the appropriate level. Small movements of the 'L' tube will cause appreciable fluid level changes, so careful adjustment will be required. The vacuum line should be connected via a waste bottle to "smooth out" any irregularity. Typically a high pressure water vacuum adapter is used, electric pumps are equally effective. A bleed valve is recommended when utilising powerful electric pumps to allow adjustments of the level of vacuum, excessive or inadequate levels will cause problems. The correct vacuum level will be found by trial and error, depending on perfusion flow rates. Try pouring a few mls of perfusion fluid into one of the chambers to see how the fluid behaves with your selected vacuum line. A good sign of stability once the perfusion system is connected up is a constant "hiss" from the exit well and a stream of fluid separated by small bubbles in the exit tube. Use an ultrasonicator to clean the 'L' tube once a week by unscrewing the plastic fitting from the chamber.

IMPORTANT NOTE

Please note that you will need to connect a vacuum line to each chamber exit tube separately and connect to the "reservoir" in parallel ie all tubes must come to connect simultaneously at the mouth of the waste "reservoir". If you connect the suction line in "series" from one exit well to the next, the control will not be achieved as one well will interfere with the next.

Peristaltic Pump

When the perfusate is re-circulated, it is common to use a peristaltic pump connected to both the input line and for removing the perfusate from the exit well. A schematic arrangement is shown below. Set the suction rate slightly higher than the inflow rate so that additional air is sucked up. This can be done by utilising larger bore tubing in the peristaltic pump mechanism for the exit line. The 'L' tube angle needs to be adjusted carefully to achieve the required fluid level, a sign of stable control is a slow stream of

Schematic of typical arrangement of peristaltic pump with BSC3 chamber

Incoming ACSF is pre-gassed and pumped in with one channel of pump into inlet 'A'. Waste is removed at 'C' from chamber using pump with larger bore tubing with second channel of pump. This can be repeated for all six chambers with a 12 channel pump. Use of larger bore tube for waste ensures that higher flow rate is used for suction, maintaining fluid level adjusted by 'L' shaped exit tube at 'C'

BSC3 CHAMBER
TOP VIEW

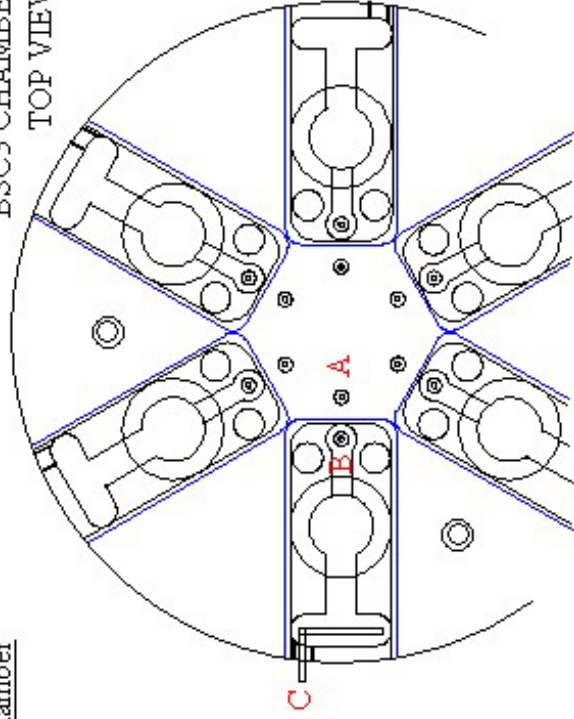

SMALL BORE PUMP TUBE

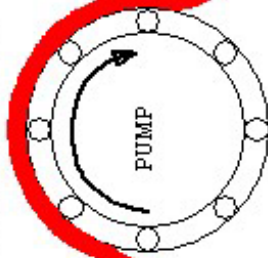

LARGE BORE PUMP TUBE

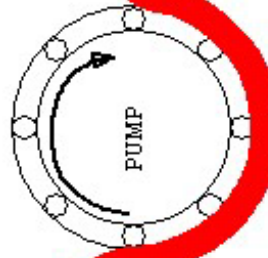

O₂/CO₂

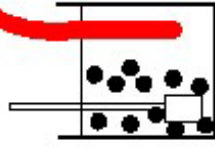

ACSF

WASTE

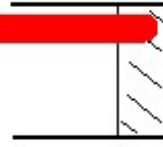

SIDE VIEW

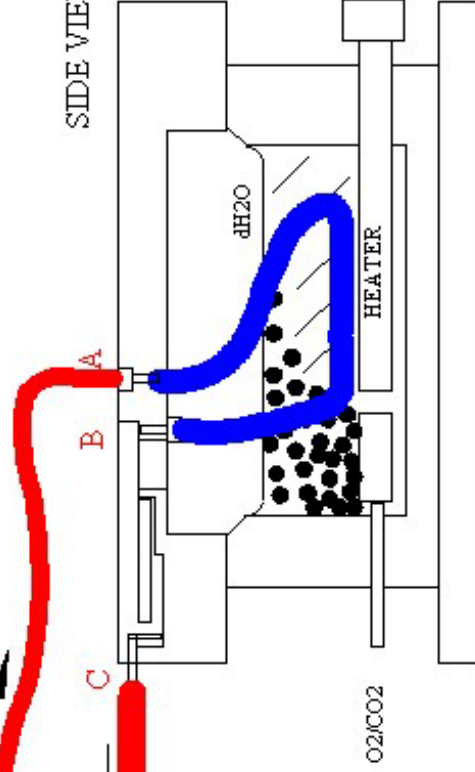

bubbles interspersed with short columns of fluid seen in a transparent plastic tube connected to the exit tube. Please note that the 'L' tube also needs to be bathed in a saline/ASCF in order to reduce the surface tension effects as mentioned above.

CONNECTION OF THE PERFUSION FLUID SOURCE

Having connected the exit well it should now be possible to connect a source of perfusion fluid to the inlet port. Typically the simplest, cheapest and most stable system is gravity feed such as a raised blood-drip set filled with the desired perfusion fluid, pre-gassed with 95% oxygen / 5% carbon dioxide gas mixture or a suitable bottle raised and bubbled constantly with the above gas mixture. If possible this should be done in a reservoir bottle kept in a water bath kept to about the temperature you will be using in the chamber eg 32 deg C is the optimum setting. This prevents the ASCF "gassing out" when it reaches the warmed chamber, often bubbles will be seen adhering under the net. Any bubbles that form in the tubing will break out as the tube enters the chamber in the inlet well. This tubing enters the chamber via a plastic connector using a silicone rubber tube overlap - this allows you to push the PTFE tube up to the surface so that bubbles breaking to the surface do not disturb the flow close to your recording electrodes. You can adjust the protrusion by opening the chamber and pushing the tube up or down more.

A blood-drip set has the advantage of allowing the flow rate to be monitored from the drip rate, in addition the flow adjustment clip is usually easy to operate. However if operating all channels of the BSC3 a multi-channel peristaltic pump will make control more manageable.

The tube entering through port [A] spirals in the lower chamber before it passes from underneath to the chamber inlet [B]. This is PTFE tubing and has a length of approx. 800mm, is 1.6mm O.D., 0.75mm I.D.

REFERENCE ELECTRODE CONNECTIONS

An earth reference electrode such as a silver/silver chloride pellet may be placed into the exit well and led out with a flexible wire to the common ground point. If excessive electrical noise problems arise, arrange for a piece of chlorided silver wire in the form of a tight spiral approx. 3 mm in overall diameter to be positioned close to the recording site on the nylon net of the insert. Alternatively form a ring of chlorided wire around the slice preparation. Noise problems usually arise from external high voltage sources such as mains power cords, computer monitors, oscilloscopes and fluorescent lights. Relocation of these potential sources may be necessary and/or shielding may be required around the recording electrode to avoid these noise problems.

The heating element in the chamber is driven by a low voltage, low noise direct current power source. If it is found that on switching off the power to the PTC03 (whilst the mains plug is still in the power socket) that noise is eliminated, check the earth connection at the mains plug and socket.

Peristaltic pumps will sometimes also generate very sharp transients due to static discharges along the silicone rubber tubing within the pump mechanism. This may be eliminated by piercing a section of connecting silicone rubber tubing (at a suitable point close to the chamber) with a piece of chlorided silver wire and earthing this to the central earthing point of the recording apparatus.

VI

MAINTENANCE

Alcohol should never be used on the slice chamber for cleaning purposes even at low concentrations because it de-hydrates and produces hair-line cracks in acrylic. A laboratory detergent which completely rinses out should be used. Heavy deposits of salts should be washed out with distilled water overnight and carbonate salts treated with mild acids such as citric acid. The most common contaminant is fungal growth in the upper section tubes and cavities. This can be avoided by agitated washing i.e. suck out plenty of distilled water intermittently with air bubbles through the tubes and holes of the chamber by use of a powerful vacuum line at the end of each experiment. Continue to dry out by using the vacuum line around all the tubes and also below the removable insert. Leaving the chamber dry will prevent the growth of foreign matter. Cover the chamber with a sheet of clean medical wipes to prevent dust settling on the surfaces. Before the start of each experiment rinse with perfusion fluid.

REPLACING NYLON NET UNDER THE 'C' INSERT

Remove the 'C' shaped insert by gently levering out the end opposite the opening of the 'C'. The old net can then be removed and discarded. Clean the rim of the 'C' insert, a mild acid such as citric or acetic will help removal of deposits, hydrogen peroxide solution will also assist removal of fungal growths. If required, use a laboratory detergent for final cleaning, wash in distilled water and leave to dry. Do not use any kind of solvent as this will permanently damage the acrylic ring.

Stretch a piece of new netting over the chamber and push the 'C' ring over the net making sure the opening of the 'C' faces the inlet. Use a new scalpel blade to trim the net around the circumference of the 'C' ring. The nylon netting is bridal veil, different grades are available if the type supplied is too fine.

Remove and clean insert and surrounding areas as described above at least once per week. At the end of each experiment, flush through the system with an agitated stream of distilled water or suck through the tubes with a powerful vacuum line ensuring agitation by allowing air to intermix with the stream of distilled water. The bubbles will assist in removal of growth lodged in the tubes of the chamber.