

"I am writing to tell you how pleased I am with the ValveBank8 Perfusion System. It's great that I can load the reservoirs, press go, and start recording. I can read papers rather than fussing with solutions and switching valves every 10-15 minutes. Since solutions are switched at exactly the same time from one experiment to the next, I have been able to automate my data analysis protocols as well."

Brain Slice Field Recording

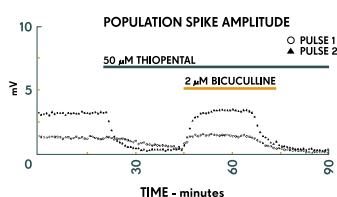

Unattended solution delivery using a ValveBank8 AutoPrime Perfusion System

Dr. M. Bruce MacIver,
M.Sc., Ph.D.

Department of Anesthesia
Stanford University
Medical Center

Increase reproducibility with fewer hours in lab.



Perfusion Systems

- Unattended solution switching**
 Avoid vibrations from switching valves by hand. The ValveBank® or ValveLink® controller handles all solution delivery so you can watch results – not switch stopcocks. Many special features are included for easy perfusion control. Low noise circuitry.
- Increased reproducibility**
 Valve switching is accurate to 0.01 seconds with programs up to 99 hours long under microprocessor control. Consistent liquid delivery means better data.
- Pinch, Teflon™ and Lee™ Valves**
 Choose between speed, cost, and ease of cleaning. Several options are available for fittings and reservoirs.
- Manual and external valve control**
 Flexible design. Easy cleaning and calibration. Slave mode valve operation controlled by your computer, pClamp, Pulse, Acquire, LabView, AxoGraph, etc.

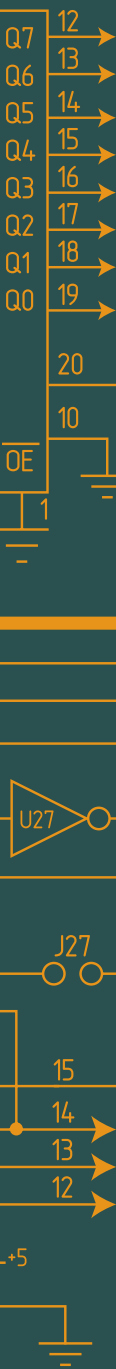

Valve Choices:

- **Pinch Valves for Reduced Maintenance**

Easiest valves to clean and switch tubing. Liquids never touch the valves. Switches in 30-50 ms. 1/32" i.d. silicone tube passes through, and is pinched closed by solenoid activation. All AutoMate Scientific valves include an individual indicator LED. Our new aluminum enclosure keeps the valves dry from spills and offers luer lock ports for syringe reservoirs.

- **Teflon™ Valves for Fast Switching**

Required for fast kinetics applications. Excellent chemical and corrosion resistance. Non-stick surface resists particles and chemical deposits. Switches in less than 10 ms, with 20 µl of dead volume from port to port. Threaded female inlet and outlet ports accept Hose Barb, Luer Lock and Nut & Ferrule fittings (see diagrams next page).

- **Lee™ Mini Valves for Extremely Fast Switching and Minimal Pressure Pulse**

For the most demanding applications AutoMate Scientific offers tiny valves from the Lee Company. Enclosed in our new aluminum box with luer locks for syringe reservoirs, these valves can open and close in 1.5-4 ms with a ValveLink8.2 controller.

Perfusion Systems Include:

Controller, valves, 60 ml syringe reservoirs and drippers (or 35 ml syringes in Teflon Luer-lock systems), 2-way stopcocks, reservoir bracket, ringstand, 1/16" i.d. tubing and four-, eight- or sixteen-into-one micro-manifold with built-in flow control. 5, 15, 35, 60 or 140 ml syringe reservoirs available.

The Economy Pinch Valve System includes a ValveLink8 controller, four pinch valves, 35 ml syringes, 2-way stopcocks, reservoir bracket, ringstand, 1/16" i.d. tubing and four-into-one micro-manifold with built-in flow control.

Computer Interfacing:

Perfusion systems can be controlled by a computer using data acquisition hardware (i.e., DigjData, ITC-16, or National Instruments board) and software (i.e., pCLAMP, Pulse, or LabView). Both ValveBanks and ValveLinks accept real-time TTL inputs to control valves. Most acquisition software already being used in your experiments can talk to our controllers. AutoMate Scientific offers an optional program called EasyCode® for the Macintosh and PC/Windows to program ValveBanks (not ValveLinks). This software is used before an experiment – valve sequences are downloaded into the memory of the ValveBank where they are run. An article by AutoMate Scientific can be found in Axon Instrument's AxoBits 17 newsletter outlining these strategies – accessible on our web site.

Pinch Valves



Teflon™ Valves



Lee™ Valves



Luer-lock Fittings in Teflon Valves



Luer-lock fittings in Teflon™ valves allow direct connection of syringe reservoirs for minimal dead volume.

Teflon™ Valve Fitting Choices

Hose Barb

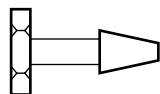

- Standard
- Available for 1/8" and 1/16" i.d. soft tubing

Lure-Lock

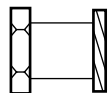

- For direct attachment of syringes
- Eliminates extra tubing between reservoirs and valves
- Includes 2-way stopcocks and 35 ml syringes

Nut & Ferrule

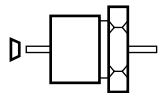

- HPLC-like, screw-in fittings for rigid, small-diameter (1/16" o.d.) tubing



Perfusion Systems Ordering Information

Part No.	Product Description	Price
17-21-20	ValveLink®4.2 Economy Pinch Valve Perfusion System	\$ 1,395
13-01-23	ValveBank®4 Teflon Perfusion System	\$ 2,395
13-pp-24	ValveBank4 Pinch Valve Perfusion System - 1/32" i.d. silicon tube	\$ 1,895
13-21-27	ValveBank4 Lee Mini Valve Perfusion System	\$ 2,595
17-01-23	ValveLink4.2 Teflon Perfusion System	\$ 2,295
17-pp-24	ValveLink4.2 Pinch Valve Perfusion System - 1/32" i.d. silicon tube	\$ 1,795
17-21-27	ValveLink4.2 Lee Mini Valve 1.5 to 4 ms Perfusion System	\$ 2,495
13-01-53	ValveBank8 Teflon Perfusion System	\$ 3,995
13-pp-54	ValveBank8 Pinch Valve Perfusion System - 1/32" i.d. silicon tube	\$ 3,195
13-21-57	ValveBank8 Lee Mini Valve Perfusion System	\$ 4,385
17-01-53	ValveLink8.2 Teflon Perfusion System	\$ 3,295
17-pp-54	ValveLink8.2 Pinch Valve Perfusion System - 1/32" i.d. silicon tube	\$ 2,495
17-21-57	ValveLink8.2 Lee Mini Valve 1.5 to 4 ms Perfusion System	\$ 3,685
17-01-83	ValveLink16.2 Teflon Perfusion System	\$ 5,995
17-pp-84	ValveLink16.2 Pinch Valve Perfusion System - 1/32" i.d. silicon tube	\$ 4,695
17-11-87	ValveLink16.2 Lee Mini Valve 1.5 to 4 ms Perfusion System	\$ 7,995

U.S./Canada prices shown. International prices add 15%. Email or visit web store for latest prices.

xx-[TB]-xx Indicate [T]op inflow and [B]ottom outflow Teflon valve fittings:
 [0]=1/8" i.d. hose barb, [1]=1/16" i.d. hose barb, [2]=Luer-lock female with stopcocks and 35 ml syringes, [3]=10-32 threaded nut & ferrules for 1/16" o.d. tubing (add \$30/set of 4), [p]=Pinch valves have no fittings

Systems include: Controller, user manual, valves, 35 ml or 60 ml syringes, stopcocks & drippers, reservoir bracket, ringstand, 1/16" i.d. Tygon tubing, and 4-, 8- or 16-into-1 micro-manifold with flow control. 5, 15, 35, 60 or 140 ml syringe reservoirs available.

Visit www.autom8.com/build_your_own.html to configure a perfusion system and quote.

Valves & Fittings Ordering Information

Part No.	Product Description	Price
	Each pair of 4 valves ordered together will be mounted in a case of 8.	
02-01-02	Set of 4 Teflon™ valves - cabled and mounted	\$ 895
02-pp-04	Set of 4 Pinch valves - cabled and mounted, 1/32" i.d. silicon tube	\$ 545
02-21-07	Set of 4 Lee mini valves - cabled and mounted	\$ 1,095
02-01-02i	Individual Teflon replacement valve	\$ 125
02-pp-04i	Individual Pinch replacement valve	\$ 90
02-21-07i	Individual Lee mini replacement valve	\$ 165
01-05	Low-noise, valve and case grounding package (per 4 valves) A grounding wire attached to all valves extending back to the controller. This item is recommended for electrophysiology and required for CE conformity.	\$ 55
02-06	Valve extension cables - 3 meter RCA M/F (set of 4 cables)	\$ 15
05-01	Luer-lock fittings - with 2-way stopcocks (set of 4)	\$ 10
05-02	Nut & ferrule fittings - for 1/16" o.d. tubing (set of 4)	\$ 30

U.S./Canada prices shown. International prices add 15%. Email or visit web store for latest prices.

02-[TB]-02 Indicate [T]op inflow and [B]ottom outflow Teflon valve fittings:
 [0]=1/8" i.d. hose barb, [1]=1/16" i.d. hose barb, [2]=Luer-lock female with stopcocks, [3]=10-32 threaded nut & ferrules for 1/16" o.d. tubing (add \$30/set of 4), [p]=Pinch valves have no fittings

Ten times faster, new protection, inputs, and event marker in a smaller box.

"Our lab has been using ValveLink controllers for years with good, reliable results. The new ValveLink8.2 is even smaller and faster than its predecessor. It also looks cool and the buttons feel nicer than the previous version. I use it manually or programmed by outputs from my stimulator. I haven't observed any noise from the valve system on my electrophysiology rig."

Hillel Adesnik, Ph.D.

Department of Cellular and
Molecular Pharmacology
University of California,
San Francisco



ValveLink8.2® Controller

- **ValveGuard™ technology detects bad valves**
Prevent damage to your ValveLink8.2® and easily observe problem valves.
- **Run experiments automatically – even unattended**
By running experiments automatically, AutoMate Scientific systems will leave you free to accomplish other tasks – saving you both time and money.
- **Microprocessor-based for accuracy and flexibility**
Our low-cost ValveLink8.2 controller has powerful perfusion commands and capabilities not offered by competing valve drivers: open single or multiple valves, master channel for control/buffer solution, computer control.
- **Low noise & low voltage valve control**
Designed for electrophysiology. CE marked for Europe.
- **Manual, TTL (digital), analog, and USB inputs**
Control valves manually (by pushbutton) or by computer – simultaneously thanks to the microprocessor design. Spill sensor protects your equipment when a leak is detected.

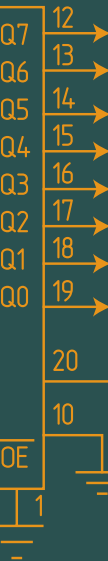

ValveLink8.2 Controller



- Manual pushbuttons
- Red/green LED indicators
- 1.5 amp, 12V AC supply included
- Dimensions: 9.28" x 1.6" x 5.13"
- Weight: 3 lbs. (1.4 kg.)



- Eight TTL inputs directly activate 8 valves
- Or control 16 valves with only four digital outputs

Additional Features

- One analog input can control eight valves
- Analog event marker allows you to record all valve activity.
- A spill sensor stops all valves when a leak is detected to protect your microscope and table. All LEDs blink until you press a button to continue.

Free ValveLink PC Software



- Control valves directly from your PC screen by USB
- Network multiple ValveLinks into a single, virtual instrument



ValveLink8.2s can switch 12V DC solenoid valves open and closed in one millisecond using full power, then hold-in at 1/2 power to prevent thermal transfer to your solutions. Low noise circuitry minimizes recording artifacts in electrophysiology. The ValveLink8.2 is less expensive than AutoMate Scientific's ValveBank controller. It is the controller of choice for dose response work at pharmaceutical companies and the NIH. Both ValveLink8.2s and ValveBanks are designed for use with pClamp, Pulse, et al. All AutoMate Scientific products include a one-year warranty.

ValveGuard™ technology detects bad valves to prevent damage to your ValveLink8.2 and easily observe problem valves. Front-panel LEDs are dark for broken or disconnected valves, or blink for short-circuited valves. Automatic networking lets you connect up to eight ValveLink8.2s to a USB hub and PC to create a single 64-channel controller. A ValveLink8.2 can power individual valves up to 1 amp (12 watts), and a total of 2 amps for all valves open simultaneously.

ValveBank or ValveLink8.2: Which controller is right for you?

Features	ValveBank	ValveLink8.2
CHANNELS	4 or 8 channels available	8 channels each, USB network to 64 channels
COMPUTER I/O	8 digital in, 8 digital out, serial (RS-232)	8 digital in, USB, analog input, event marker out
DIGITAL INPUTS	One pulse can start a ValveBank program, or TTL inputs each control 1 valve	One TTL input per valve, or demultiplex and control up to 16 valves with 4 inputs
PROGRAMMABLE	Yes- ValveBank keypad, EasyCode software or digital outputs from your data acquisition software	Only using real-time analog or digital outputs from your computer / data acquisition software.
SOFTWARE	Mac and PC "EasyCode" software to pre-program ValveBanks (up to 16 ch.)	Free Windows XP real-time USB control and networking software for up to 64 valves at once
MANUAL CONTROL	External keypad	Front panel buttons
MANUAL FEATURES	1-on, master channel, timed open, TTL outputs	1-on, master channel
SPEED	10 milliseconds	1 millisecond
VALVE POWER	4 watts per channel or 8 watts total	Up to 12 watts (1 amp) per channel, 24 watts (2 amps) total
PRICE	Higher	Lower

ValveLink8.2 Controller Ordering Information

Part No.	Product Description	Price
01-18	ValveLink®8.2 digital/manual controller	\$ 995
01-26	ValveLink®16.2 digital/manual controller	\$ 1,895
01-19	BNC cable - ValveLink8.2 to pCLAMP/Digidata, et al., 4 BNC plugs to DB-9	\$ 55
01-27	BNC cable - ValveLink16.2 to pCLAMP/Digidata, et al., 5 BNC plugs to DB-15	\$ 85
01-29	USB cable - USB-A male, USB-B male 10' cable	\$ 9
01-30	USB hub - 4 port unpowered	\$ 24
01-17	Rack-mounting brackets - ValveLink8.2 to standard 19" rack	\$ 20
01-25	Rack-mounting brackets - ValveLink16 to standard 19" rack	\$ 35
	Cables for Heka/InstruTECH and LabView	\$ call

U.S./Canada prices shown. International prices add 15%. Email or visit web store for latest prices.

Behind every great perfusion system is a reliable valve controller.



"We use the ValveBank in electrophysiology on a Xenopus oocyte recording rig. We have run a twelve-channel manual perfusion delivery system for several years with timed solenoid valves. The ValveBank and accompanying EasyCode Macintosh software allow us to program full wash and delivery sequences in advance with significantly more accurate switching. The new manual perfusion timing option allowed the ValveBank to perform exactly like the controller we had built before. Basically, the ValveBank saves us the worries of monitoring reagent-delivery, and it works."

Dr. David Julius

Department of Cellular and
Molecular Pharmacology
University of California,
San Francisco

ValveBank® Controller

- **Run experiments automatically – even unattended**
By running experiments automatically, AutoMate Scientific systems will leave you free to accomplish other tasks – saving you both time and money.
- **Microprocessor-based for accuracy and flexibility**
The ValveBank® can store sixteen user programs with 10 millisecond switching accuracy. It includes powerful perfusion commands and capabilities not offered by competing valve drivers: open single or multiple valves, master channel for control/buffer solution, and computer control.
- **Low noise & low voltage valve control**
Designed for electrophysiology. CE marked for Europe.
- **Manual, TTL (digital), and serial (RS-232) inputs**
Control valves manually (by keypad) or by computer – simultaneously thanks to the microprocessor design.
- **Low cost & low profile, simple design**
Optional BNC cables and 19" rack-mounting brackets.

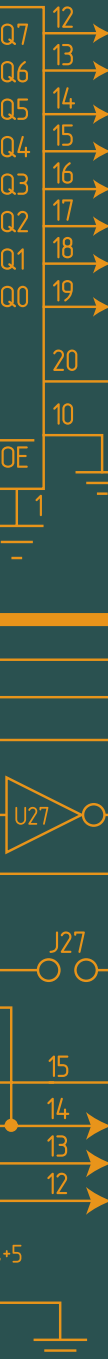

ValveBank4 & 8

- Dimensions: 10" x 7.5" x 2"
Weight: 5 lbs. (2.27 kg.)



- User-selectable for normally open or closed valves
- 1.5 amp, 12V AC power supply included

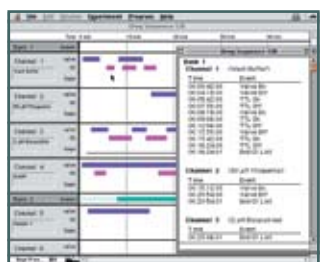

- Back-lit LCD display
- Detached 16-key membrane keypad
- Easy menu-driven interface
- 16 or 32 user programs of 256 commands up to 99 hours long

EasyCode Software

- Program up to sixteen channels of valves and digital outputs.
- Open multiple experiment windows. List sequences to screen or printer. Copy and paste. Zoom in and out of your experiment. Please see page 14.

CE
AutoMate Scientific®
READY FOR RESEARCH.™

All AutoMate Scientific valve controllers switch 12V DC solenoid valves open and closed rapidly using full power, then hold-in at 1/2 power to prevent thermal transfer to your solutions. Low noise circuitry minimizes recording artifacts in electrophysiology. ValveBanks are designed for use with pClamp, Pulse, et al. All AutoMate Scientific products include a one-year warranty.

The ValveBank® remains the only programmable valve controller for physiology that does not require a computer. ValveBanks include digital and manual control, plus programming through their keypad and LCD screen or EasyCode® software from a Macintosh or PC. ValveBanks run user valve sequences without a computer and include eight programmable digital outputs for control of external devices such as stimulators, pumps and recording devices. Entire ValveBank programs can even be triggered by a single TTL pulse.

EasyCode® - Expand the computing power of your ValveBank

Optional EasyCode software helps you program your ValveBank with a Mac or PC-Windows using easy "click-and-drag" time bars. Download your valve sequences into the ValveBank's memory with the included cable. Run programs on the ValveBank, which can be disconnected from the computer.

ValveBank or ValveLink8.2: Which controller is right for you?

Features	ValveBank	ValveLink8.2
CHANNELS	4 or 8 channels available	8 channels each, USB network to 64 channels
COMPUTER I/O	8 digital in, 8 digital out, serial (RS-232)	8 digital in, USB, analog input, event marker out
DIGITAL INPUTS	One pulse can start a ValveBank program, or TTL inputs each control 1 valve	One TTL input per valve, or demultiplex and control up to 16 valves with 4 inputs
PROGRAMMABLE	Yes- ValveBank keypad, EasyCode software or digital outputs from your data acquisition software	Only using real-time analog or digital outputs from your computer / data acquisition software.
SOFTWARE	Mac and PC "EasyCode" software to pre-program ValveBanks (up to 16 ch.)	Free Windows XP real-time USB control and networking software for up to 64 valves at once
MANUAL CONTROL	External keypad	Front panel buttons
MANUAL FEATURES	1-on, master channel, timed open, TTL outputs	1-on, master channel
SPEED	10 milliseconds	1 millisecond
VALVE POWER	4 watts per channel or 8 watts total	Up to 12 watts (1 amp) per channel, 24 watts (2 amps) total
PRICE	Higher	Lower

ValveBank Controller Ordering Information

Part No.	Product Description	Price
01-01	ValveBank®4 programmable controller	\$ 1,095
01-08	ValveBank®8 programmable controller	\$ 1,695
01-09	BNC cable - ValveBank to pCLAMP/Digidata, et al., 4 BNC plugs to DB-25	\$ 55
01-07	Rack-mounting brackets - ValveBank to standard 19" rack	\$ 20
01-06	ValveBank keypad 6' extension cable	\$ 20
	Cables for Heka/InstruTECH and LabView	\$ call

U.S./Canada prices shown. International prices add 15%. Email or visit web store for latest prices.

800.998.MATE | www.autom8.com | 650 University Ave #5, Berkeley, CA 94710 USA
tel 510.845.6283 | fax 510.665.3975 | e-mail info@autom8.com

Save time by purchasing
disposable perfusion
accessories from one source.

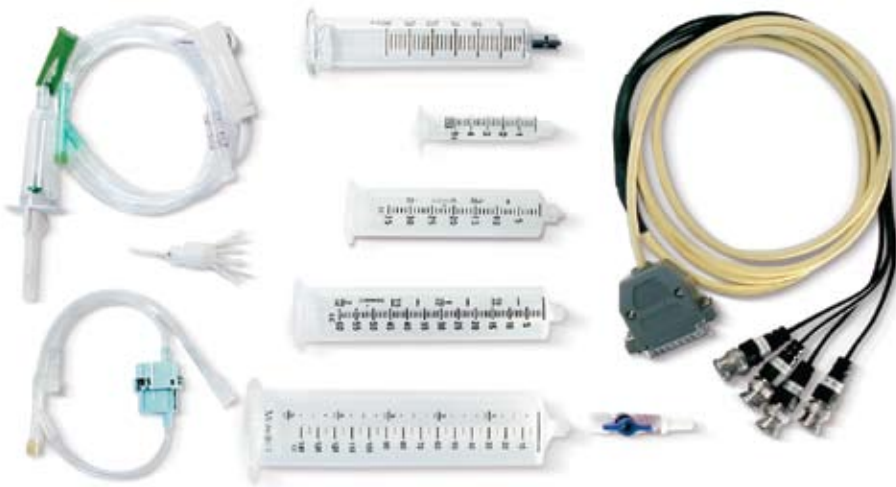

Perfusion Accessories

Syringe reservoirs

Replacement syringes and reservoirs are available for all perfusion systems. Luer lock 5, 15, 35, 60 and 140 ml plastic syringe reservoirs are standard. 35 ml glass syringes and Teflon tubing are available with our "Volatiles Pressure Upgrade" for researchers with volatile agents in solution. 800 ml beakers with luer lock fittings are available as replacements for the In Vivo Perfusion System.



Pressurized reservoirs

Custom, closed, pressurized Nalgene HDPE reservoir bottles are available in 1, 2, and 10 liter sizes with ringstand holders. Why keep refilling buffer all day? These require an AutoMate Scientific Pressurized Perfusion System or regulated pressure source.

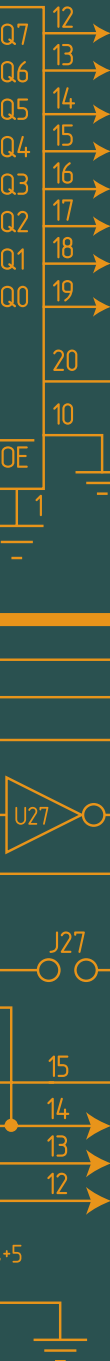



Micro-manifolds and stoppers

4-, 8-, and 16-into-1 Teflon™ micro-manifolds for bath perfusion combine multiple tubes (1/16" (1.6 mm) i.d. or o.d.) into a single outflow tube. The manifolds include a built-in flow adjustment screw to decrease flow rate without adding dead volume. The 1/4 inch (6.35 mm) outflow is interchangeable with manifolds from Warner Instruments and all AutoMate Scientific perfusion chambers. Teflon™ Stoppers are available to temporarily close unneeded holes.



Hospital I.V. perfusion accessories

Disposable hospital I.V. drippers (drip chambers) get flow started in empty tubes and help visualize flow rates. Flow regulators restrict perfusion flow rates like the adjustment screw in our micro-manifolds. They are helpful in matching perfusion inflow rate to outflow rate. Both use 1/8" i.d. tubing. Case pricing available.



Perfusion reservoir gas bubbler

Available with or without an oxygen-safe regulator, the Perfusion reservoir gas bubbler is used to split a gas bottle like oxygen, carbogen, or CO₂ into multiple perfusion reservoirs. The included high-quality stones create a stream of fine bubbles to evenly saturate your solutions with gas. Each gas line can be individually adjusted. Replacement stones also available.



Tubing

Tygon, Teflon™, Silicone pinch valve, and Polyethylene tubing available in any length over 10 feet (3 meters).



Vacuum pump and trap

For labs without an easy vacuum source we offer a quiet Lab-duty oil-free vacuum pump with muffler for both 110V and 220V mains. Our large 10 liter polypropylene Vacuum Trap means you won't have to empty it as often. This Nalgene bottle includes easy luer lock fittings for vacuum tube connections and all necessary tubing to the pump and chamber.

Perfusion Accessories and Tubing Ordering Information

Part No.	Product Description	Price
06-05c	Case of 50x 5 ml syringes	\$ 18
06-15c	Case of 80x 15 ml syringes	\$ 29
06-30c	Case of 30x 35 ml syringes	\$ 36
06-60c	Case of 20x 60 ml syringes	\$ 32
06-140c	Case of 20x 140 ml syringes	\$ 180
06-1Kp	Pressurized 1 Liter reservoir with bracket, fittings & tube (requires pressure)	\$ 63
06-2Kp	Pressurized 2 Liter reservoir with bracket, fittings & tube (requires pressure)	\$ 84
06-10Kp	Pressurized 10 Liter reservoir with fittings & tube (requires pressure)	\$ 112
05-04	Micro-manifold, 4-into-1 Teflon with flow control	\$ 63
05-08	Micro-manifold, 8-into-1 Teflon with flow control	\$ 84
05-16	Micro-manifold, 16-into-1 Teflon with flow control	\$ 112
05-05	Micro-manifold stoppers (set of four)	\$ 16
06-21	Disposable flow regulator	\$ 20
06-21c	Case of 48x disposable flow regulators	\$ 715
06-04	Disposable drippers (set of 4)	\$ 42
06-04c	Case of 48x disposable drippers	\$ 320
01-34	Regulated perfusion reservoir gas bubbler - 4 channel	\$ 440
01-35	Un-regulated perfusion reservoir gas bubbler - 4 channel	\$ 75
01-36	Regulated perfusion reservoir gas bubbler - 8 channel	\$ 475
01-39	Un-regulated perfusion reservoir gas bubbler - 8 channel	\$ 115
01-40	Bubbler stones - set of 4	\$ 9.50
05-11	Tygon vinyl tubing - 1/16" i.d.	\$ 0.52/ft
05-13	Teflon tubing - 1/16" o.d. for use with nut & ferrule fittings	\$ 3.15/ft
05-14	Silicon pinch valve tubing - 1/32" i.d. x 1/16" o.d.	\$ 2.00/ft
04-09	10 Liter vacuum trap with lure-lock connections and tubing	\$ 295
vac	Lab-duty oil-free vacuum pump (115 VAC)	\$ 499

U.S./Canada prices shown. International prices add 15%. Email or visit web store for latest prices.
 First set of disposables included in perfusion systems. Please order a minimum of 10' of tubing.



"The EasyCode software you provided is simple to use. We use a large screen Macintosh for creating and storing protocols. We especially like the ability to create new protocols and download them directly to the ValveBank, it really couldn't be easier."

Dr. Susan Abrahamson
University of California,
Berkeley

EasyCode Dialog Box

Start Time: 00:00:08.40
End Time: 00:01:54.00
Iterations: 2

Loop Options
 Multi-Channel
 Channel 1
 Channel 2
 Channel 3
 Channel 4

OK Cancel

- Enter start and stop times accurate to 0.01 sec.
- Use all ValveBank commands including multi-channel looping and interface triggering

Free your computer during experiments

Transfer and run programs stored in the ValveBank, which can be disconnected from the computer – leaving it available for data acquisition.

Expand the computing power of your ValveBank system.

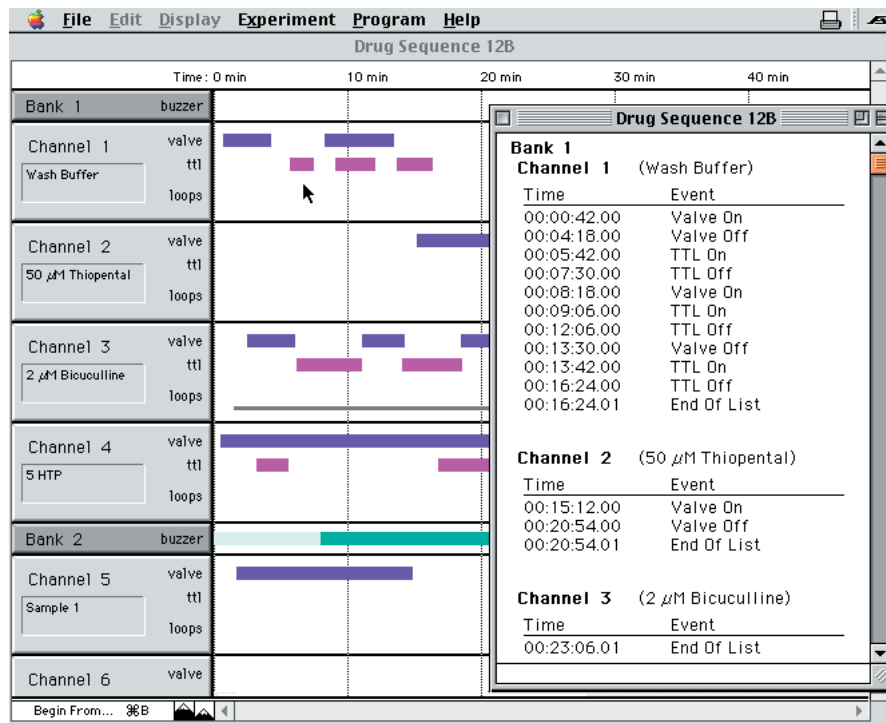

EasyCode® Software

Program your ValveBank® with a Macintosh or PC using easy "click-and-drag" time bars. Save and load unlimited programs to disk, print out program listings, then download your sequences into the ValveBank's memory with the included serial cable in one simple step.

- **Program up to sixteen channels of valves and digital outputs**
Open multiple experiment windows. List sequences to screen or printer. Copy and paste. Zoom in and out of your experiment.

EasyCode Software Ordering Information

Part No.	Product Description	Price
01-02	EasyCode® Mac - ValveBank programming software Macintosh OS 6-9 & Classic with Mini-DIN serial cable	\$ 195
01-02-USB	EasyCode® Mac - ValveBank programming software Macintosh OS 6-9 & Classic with USB-to-serial adapter	\$ 274
01-03	EasyCode® PC - ValveBank programming software - Windows 3.1-95	\$ 195
01-03-2000	EasyCode® PC - ValveBank programming software - Windows 98-XP	\$ 249
USB	USB to serial converter - PC or Macintosh	\$ 79

U.S./Canada prices shown. International prices add 15%. Email or visit web store for latest prices.

AutoMate Scientific®
READY FOR RESEARCH.™

800.998.MATE | www.autom8.com | 650 University Ave #5, Berkeley, CA 94710 USA
tel 510.845.6283 | fax 510.665.3975 | e-mail info@autom8.com

Precise control for whole-cell or single-cell superfusion.



Pressurized Superfusion

For anyone who needs:

- **Faster switching and steady flow**
- **Fine microliter perfusion and microinjecting**

Easy to add to any new or existing gravity perfusion system from AutoMate Scientific, any third-party manufacturer, or even homemade rigs. Connect to house air or compressor (30 to 100 psi). Does not introduce bubbles into solution; helps overcome flow problems due to bubbles. Available in four-, eight- or sixteen-channel configurations. Syringe reservoirs may be placed in a water bath for temperature control. Elegant design allows individual control of each air line.

Liquid Switching in 3-4 msec.

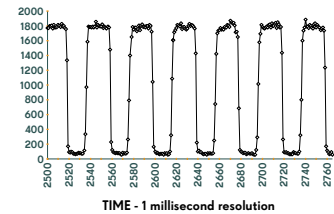

Fast Flow Rhodamine B Fluorescence Switching - 40 ms period using the AutoMate Scientific Pressurized Perfusion System at 2 psi

Thilo Lacoste

Materials Science Division
Lawrence Berkeley National
Laboratory

Precision Components



- 5 micron filter and gauge
- Precision regulator delivers 0-10 psi



Several sizes of plastic syringe reservoirs or 35 ml glass syringes and Teflon tubing as our "Volatiles Pressure Upgrade."

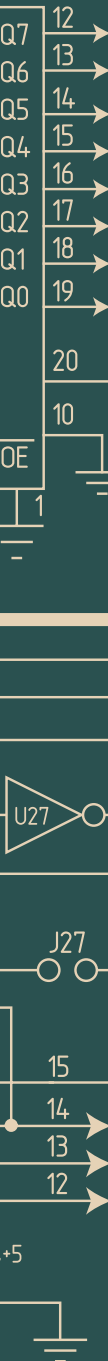

Rubber Stoppers



Pressure Upgrade available with 35 or 60 ml syringes and rubber stoppers shown in this photo, or 50 ml screw-cap reservoirs shown in large photo on page 15.

Pressurized Superfusion Ordering Information

Part No.	Product Description	Price
09-04	Perfusion Pressure Upgrade - 4 channel	\$ 450
09-08	Perfusion Pressure Upgrade - 8 channel	\$ 550
09-16	Perfusion Pressure Upgrade - 16 channel	\$ 850
	with 35 or 60 ml plastic syringes, filter, regulator, and manifolds	
09-04n	Perfusion Pressure Upgrade - 4x 50 ml screw-cap reservoirs	\$ 450
09-08n	Perfusion Pressure Upgrade - 8x 50 ml screw-cap reservoirs	\$ 550
09-16n	Perfusion Pressure Upgrade - 16x 50 ml screw-cap reservoirs	\$ 850
06-50	Replacement 50ml screw-cap reservoir	\$ 12
	with 50ml plastic screw-cap reservoirs, filter, regulator, and manifolds	
09-04v	Volatiles Pressure Upgrade - 4 channel	\$ 595
09-08v	Volatiles Pressure Upgrade - 8 channel	\$ 850
09-16v	Volatiles Pressure Upgrade - 16 channel	\$ 1295
	with 35 ml glass syringes, Teflon tube, filter, regulator and manifolds	

U.S./Canada prices shown. International prices add 15%. Email or visit web store for latest prices.



Liquid switching times in milliseconds without moving sewer pipes.



Perfusion Pencil® Multi-Barrel Manifold Tip

- **Rapid solution change with micro-liter dead volume**
No piezo or stepper motor translation. No clumsy rotating valves.
- **Single-cell and patch delivery**
For mounting on any micromanipulator. Easy to connect and clean.
- **Vacuum cross-contamination prevention**
Use one tube to vacuum the tip volume clear between solution changes.

Perfusion Pencil® Ordering Information

Part No.	Product Description	Price
04-04-[x]	Multi-barrel Perfusion Pencil® - 4-into-1 with 100, 250 or 360 µm i.d. tip	\$ 225
04-08-[x]	Multi-barrel Perfusion Pencil® - 8-into-1 with tip	\$ 225
04-16-[x]	Multi-barrel Perfusion Pencil® - 16-into-1 with tip	\$ 350
04-[x]	Replacement removable tips	\$ 30
	[x] = specify -100, -250, or -360 µm i.d. removable tip	

U.S./Canada prices shown. International prices add 15%. Email or visit web store for latest prices.

800.998.MATE | www.autom8.com | 650 University Ave #5, Berkeley, CA 94710 USA
tel 510.845.6283 | fax 510.665.3975 | e-mail info@autom8.com

Pencil Tip Cross Section



4 to 16 micro-bore tubes into
1 outflow

360 Micron Removable Tip

Flow rates (±0.05):

Gravity 1.15 ml/min
2 psi 3.98 ml/min
8 psi 10.66 ml/min

250 Micron Removable Tip



Flow rates (±0.05):

Gravity .35 ml/min
2 psi 1.66 ml/min
8 psi 5.16 ml/min

100 Micron Removable Tip



Flow rates:

Gravity zero flow
2 psi 0.07 ml/min
8 psi 0.25 ml/min

100, 250 and 360 micron internal diameter removable delivery tips available



Heated Perfusion Pencil with Neoprene Sleeve Removed

Easy luer-lock connections and manipulator mounting. Thermodynamic design maintains temperature with 5 ml/minute flow from both tips without any metal tubing.

Temperature Sensors Included

Separate chamber bath and Perfusion Pencil thermocouples included.

See previous page for flow rates.

Accurate temperature control, rapid solution switching and fast wash-out.

**ThermoClamp™-1 Temperature Control System**

- Combination inline heater plus multi-channel focal drug delivery**
 Maintain bath temperature and rapid drug wash-out with a high-flow bath line while quickly switching 4-8 preheated solutions through the Perfusion Pencil.® Steady 37°C at 5 ml/minute flow rates through both the bath line and tip.
- Advanced auto-tuning temperature lock**
 Fuzzy logic PID software maintains chamber or reagent temperature to within 1°C of setpoint or better. The ThermoClamp calibrates its own tuning for ideal temperature control - no need to guess "loop speed" settings.
- Designed for physiology research**
 No metal anywhere in the flow path - unlike some competitors. Low noise for electrophysiology with internal and external grounding plus electrical isolation between liquids and heating elements.
- Ready to use**
 Includes everything you need for heated perfusion: power supply, temperature sensors, and inline heater with easy luer lock tube connections.

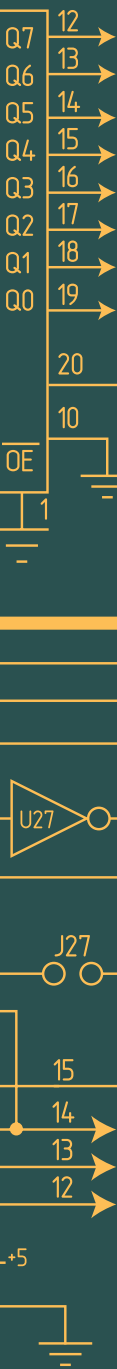

You can have rapid switching, fast wash-out, and accurate temperature control at the same time. Set the ThermoClamp temperature from ambient to 50°C. A front-panel BNC provides an analog output of current temperature for recording. Different sizes of replaceable tips are interchangeable with our standard Perfusion Pencil. The tips have microliter dead volume for rapid switching. No messy water jacket is required, but the separate high-flow line is capable of heating a perfusion chamber with water jacket if desired.

Do you need to change your prep's temperature over the course of an experiment? A programmable "ramp and hold" feature can automatically vary the setpoint over time. The ThermoClamp system includes bath and Perfusion Pencil thermocouple sensors. Automatic overtemp and thermocouple failure protection alerts you to any problems. Incorporate temperature control into your perfusion rig with simple micromanipulator mounting.

Operation

Connect multiple reagent tubes from any perfusion system to the heated Perfusion Pencil on a manipulator directed into your chamber. If desired, connect a separate buffer line to the "high-flow" bath luer connection on the Pencil, and the outflow to your chamber. If your chamber includes a water jacket, you can use the high-flow line with a constant flow of water to heat the chamber. Place the bath thermocouple sensor in the chamber. Set your desired temperature on the controller and begin liquid flow. The ThermoClamp monitors bath temperature and heats the liquids flowing through the Perfusion Pencil keeping the chamber at exactly the desired temperature. Your perfusion system can quickly change solutions through the Perfusion Pencil tip and also deliver buffer for fast wash-out. Sophisticated circuitry will "auto tune" the ThermoClamp heating parameters based on your flow rates, chamber, and tubing to clamp the temperature and minimize over/undershoot.

ThermoClamp™ Temperature Control System Ordering Information

Part No.	Product Description	Price
03-11-LL	ThermoClamp™1 - 1 channel with controller, heated Pencil and sensors	\$ 1,270
03-14-[x]	ThermoClamp™1 - 4 channel with controller, heated Pencil and sensors	\$ 1,470
03-18-[x]	ThermoClamp™1 - 8 channel with controller, heated Pencil and sensors	\$ 1,470
	[x] = specify -100, -250, or -360 µm i.d. removable tip	
01-17b	Rack-mounting brackets - ThermoClamp to 19" rack	\$ 20

U.S./Canada prices shown. International prices add 15%. Email or visit web store for latest prices. Manipulator not included.

Easy to Read or Record



- Large LCD 0.1°C temperature display
- Analog temperature output

ThermoClamp-1



- Dimensions: 11.5" x 2" x 7"
- Weight: 4 lbs. (1.8 kg.)



Low noise - designed for electrophysiology.



"I just wanted to tell you that I have been using the SmartSquirt nearly every day, and I am very pleased with it. I have tested for cross contamination, and I believe it is very low. To prevent hydrostatic flow from the cryostat tubes into the bath, one line must continue perfusing bath solution after all other valves are closed. Your design changes help hold all of the fittings tightly and keep them from leaking or flowing backwards. I would also rate your company as being excellent for your immediate response to problems and questions on your products."

Dr. John G. Starkus

The Queen's Medical Center
Honolulu, Hawaii

Perfuse microliter volumes of precious solutions.



SmartSquirt® Micro-Perfusion System

- **Deliver as little as 100 microliters of precious drugs**
Switch between eight solutions in milliseconds from a single tip.
- **Valves and pressure controls in a small box near microscope - no stand necessary**
Includes pressurized large-volume reservoir for buffer.

Programmable dispensing, microinjection, perfusion or spritzing of reproducible microliter volumes. Up to eight solutions are stored in cryo tubes with easy syringe refill ports. Included pneumatic valves deliver regulated air pressure to push liquids out of the SmartSquirt Perfusion Pencil tip. An AutoMate Scientific (or other) valve controller offers programmable, manual or computer-controlled valve selection for switching which reagent is delivered from the tip. Pulse a valve quickly for microliter delivery, or leave it on for constant perfusion. The short delivery path saves expensive reagents. Integrated BackStop™ check valves prevent backflow found in competing micro-perfusion systems.

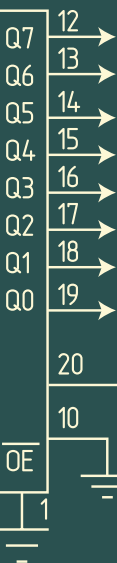

SmartSquirt® Micro-Perfusion System Ordering Information

Part No.	Product Description	Price
07-04-[x]	SmartSquirt®4 Micro-Perfusion System	\$ 1,650
07-08-[x]	SmartSquirt8 Micro-Perfusion System - SmartSquirt Valve Pressure Unit, Reservoir Block & Perfusion Pencil	\$ 2,049
	SmartSquirt Systems with Valve Controllers	
07-VL-04-[x]	SmartSquirt4 ValveLink Micro-Perfusion System	\$ 2,595
07-VL-08-[x]	SmartSquirt8 ValveLink Micro-Perfusion System	\$ 2,995
07-VB-04-[x]	SmartSquirt4 ValveBank Micro-Perfusion System	\$ 2,695
07-VB-08-[x]	SmartSquirt8 ValveBank Micro-Perfusion System	\$ 3,695
	[x] = specify -100, -250, or -360 µm i.d. removable tip	
06-25	SmartSquirt Cryo vials - 2.5 ml - Qty 8	\$ 3
06-25c	SmartSquirt Cryo vials - 2.5 ml - Bag of 100	\$ 25
02-01-05i	Replacement SmartSquirt Valve	\$ 59
05-07	Colored SmartSquirt Tubing - 1/16" i.d. (per foot)	\$ 4

U.S./Canada prices shown. International prices add 15%. Email or visit web store for latest prices. Manipulator not included.

SmartSquirt Reservoir Block



- Uses standard 2.5 ml cryo-tubes as reservoirs
- Minimize cross-contamination with BackStop™ back-flow prevention: one-way check valves inside the reservoir block prevent liquid backflow from the tip
- Easy ports for refilling reservoirs
- Convenient manipulator mounting
- Luer lock tips are interchangeable with our standard Perfusion Pencil®

Integrated Pressure Regulator



Precision regulator, gauge, 5 micron filter and electric valves are built-in.

See page 17 for flow rates.



Oocyte Chamber Diagram

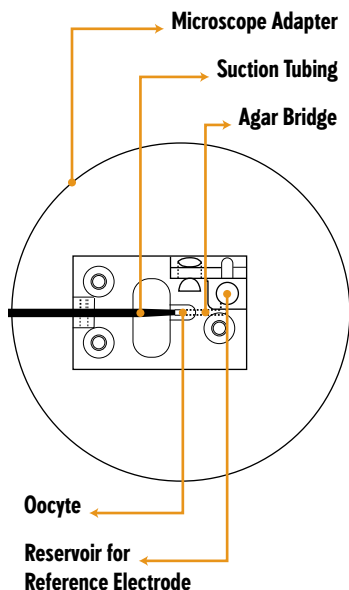

- Integrated outflow tube and agar bridge
- Chamber dimensions: 45 x 30 x 10 mm
- New slot for virtual ground electrode

Oocyte Chamber Side View

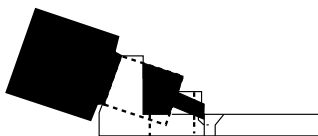

Insert micro-manifold for very low dead space

Low working volume means fast exchange times.

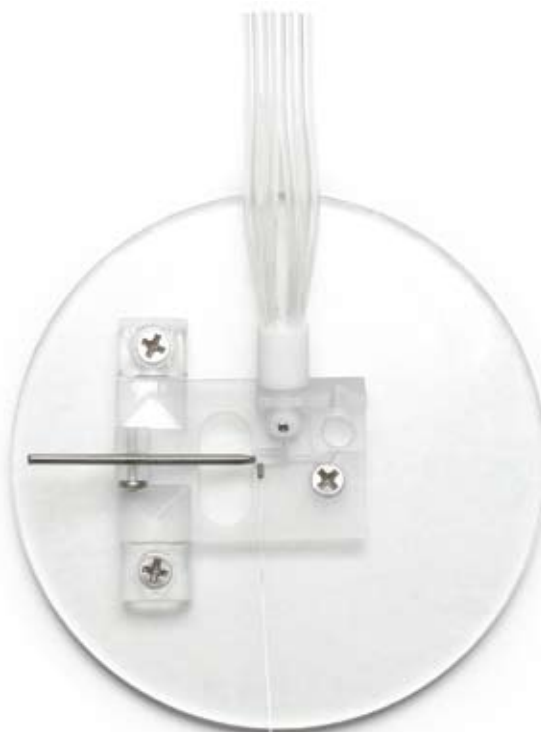

Oocyte Perfusion Chamber

- Small working volume (< 20 μ l)
- Fast solution exchange

Expression of recombinant receptors in oocytes has been a favorite choice for researchers to assess the pharmacology of signal transduction pathways. Since the oocytes are 1 - 1.5 mm in diameter, however, fast solution exchange around the oocyte was difficult. After several years of electrophysiological research, we have designed a *Xenopus* oocyte perfusion chamber for use in automated and unattended experiments. Combined with an automated perfusion system, this chamber allows researchers to obtain dose-response data quickly and easily.

Oocyte Perfusion Chamber Ordering Information

Part No.	Product Description	Price
OPC-1	Oocyte perfusion chamber - specify 80, 90, 100, or 120 mm stage adapter (Micro-manifold also recommended)	\$ 185

U.S./Canada prices shown. International prices add 15%. Email or visit web store for latest prices.

800.998.MATE | www.autom8.com | 650 University Ave #5, Berkeley, CA 94710 USA
tel 510.845.6283 | fax 510.665.3975 | e-mail info@autom8.com

Q7 12
Q6 13
Q5 14
Q4 15
Q3 16
Q2 17
Q1 18
Q0 19
20
10
OE
1
U27
J27
15
14
13
12
+5

Why transfer to coverslips?



"We do, indeed, get a rapid change of solution (depending, of course, on the adjusted fluid level), with mechanical stability otherwise very good, and no problems with noise, and the system is otherwise rather easy to set up. I could confidently recommend it to any investigator who works with cells that adhere strongly to the substrate."

Dr. Jonathan E. Freedman, Ph.D.

Department of
Pharmaceutical Sciences
Northeastern University

Petri Dish Perfusion Chamber

- Perfuse cells right in your Petri dish**

Cells cultured in Petri dishes are a popular research tool used in applications from patch clamping to intracellular ion probe imaging. True perfusion (continuous inflow and outflow) of solutions in the dish can be difficult to configure. This forces scientists to plate cells on cover slips for placement into specially designed perfusion chambers. The PCP-1 chamber was designed by scientists after years of patch clamp research to overcome this problem. Perfuse cells right in your Petri dish with any perfusion system and an optional Teflon manifold (sold separately). Ideal for inverted microscopy using optically clear Petri dishes. Adjustable metal suction tube included. Dimensions: 35 mm outside dia. x 20 mm tall.

Petri Chamber Diagram

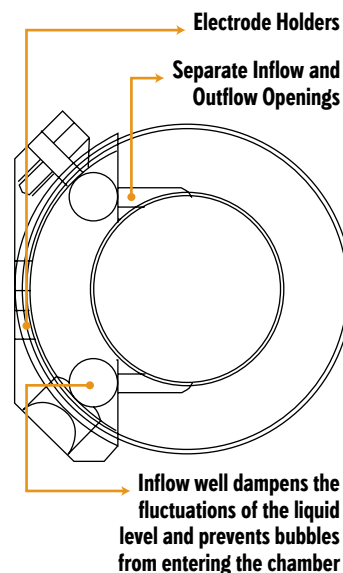

Petri Dish Perfusion Chamber Ordering Information

Part No.	Product Description	Price
PCP-1	Petri dish perfusion chamber insert - optional specify Corning, Falcon, Nunc (Micro-manifold also recommended)	\$ 195

U.S./Canada prices shown. International prices add 15%. Email or visit web store for latest prices.

800.998.MATE | www.autom8.com | 650 University Ave #5, Berkeley, CA 94710 USA
tel 510.845.6283 | fax 510.665.3975 | e-mail info@autom8.com

AutoMate Scientific®
READY FOR RESEARCH.™

