

Panel Rail Mounted Heavy Duty Shelf

- Allows easy rack mounting of narrow equipment or items that do not have rack mounting capabilities.
- Shelves feature formed 14-gauge steel construction
- 15" Deep x 3.5" (2U) high = 100 pound weight load rating
- Rear lip stiffener folded up for extra strength & acts as a rear equipment retainer
- Mounts to rack rails either as an internal shelf or external shelf/work area
- Rugged textured - powder paint finish
- Requires mounting hardware



Flat Pack Shipping

Shipped in a flat pack container for handling ease & protection. Perfect for tight access areas or 1 person installations.

Rack is knocked down into 5 easy to handle parts (ie...two sides, top, bottom and a pack of 4 panel rails)

Panel Rails



Floor-standing and table-top equipment racks.



Floor-standing Equipment Rack

- Standard 19" panel width (21.34" wide overall)
- Usable depth of 16.5" (17.5" deep overall)
- Knockdown rack unit is shipped in a flat pack container for handling ease & protection (see above)
- Perfect for tight access areas or 1 person installations as unit is knocked down into 5 easy to handle parts (ie...2 sides, top, bottom and 4 rails)
- Complete with; 4 infinitely adjustable - combination rack mount rails, on E.I.A. universal spacing (5/8 - 5/8 - 1/2 inch) - drilled & tapped for 10-32 screws (see close up right) and 4 leveling feet
- Removable gland plate (over 10" long X 1.5" high opening) with knockouts on rear bottom of rack for easy cable access
- Simple assembly using one bolt in each corner to lock the sides to the top and bottom (hardware included)
- Heavy duty 16 gauge steel top, bottom and sides
- Rails are made of 10 gauge steel (zinc plated finish for grounding capabilities)
- Recommended maximum weight, 1,000 pounds
- Finished in rugged textured powder paint



Table-Top Equipment Rack

Features

- Standard 19" rack panel width mounting
- Rack mounting, on E.I.A. universal spacing (5/8 - 5/8 - 1/2 inch)
- Round hole punched for 10-32 clip nuts (included)
- Choice of two heights, 21" (12U) or 28" (16U)
- Heavy duty construction, 14 gauge steel
- Supplied unassembled (four pieces), shipped in a flat pack container for handling ease & protection
- Includes all hardware and four rubber feet
- Recommended maximum weight (RRTT1928 tested) - 350 pounds
- Rugged powder paint, textured black finish

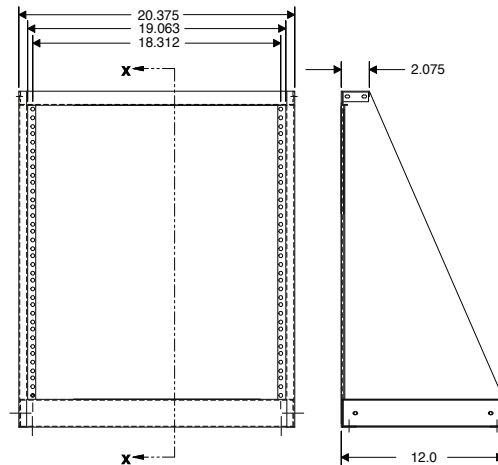

Light Duty Shelf

- Allows easy rack mounting of narrow equipment or items that do not have rack mounting capabilities.
- Mounts to rack rails either as an internal shelf or external shelf/work area (e.g. for a keyboard)
- Shelves feature formed 16-gauge steel construction
- 7" Deep x 1.75" (1U) high = 40 pound weight load rating
- Front & back edge folded - acting as both stiffeners and equipment retainers
- Shelves include tie down slots on each side & four tie down holes
- Rugged textured - black powder paint finish
- Requires mounting hardware



Ordering Information

Part No.	Equipment Racks and Shelves
FR-TT21	Table-top rack - short 21" (12U) tall x 19" wide rack
FR-TT28	Table-top rack - tall 28" (16U) tall x 19" wide rack
FR-TT-Shelf	Table-top Rack Shelf 7" deep x 19" wide rack x 1.75" tall
FR-EQ35	Equipment Rack 35" (20 U) tall x 19" wide rack x 16.5" deep
FR-EQ42	Equipment Rack 42" (24 U) tall x 19" wide rack x 16.5" deep
FR-EQ63	Equipment Rack 63" (36 U) tall x 19" wide rack x 16.5" deep
FR-EQ-Shelf	Equipment Rack Shelf 15" deep x 19" wide rack x 3.47" tall
FR-1425PHD	Equipment rack casters - Heavy duty (600 lbs) set of 4
FR-1425PL	Equipment rack casters - Light duty (400 lbs) set of 4
	More sizes and accessories available. Contact AutoMate.

U.S./Canada prices shown. International prices add 15%. Email or visit web store for latest prices.